

Schaltbild
Connection diagram

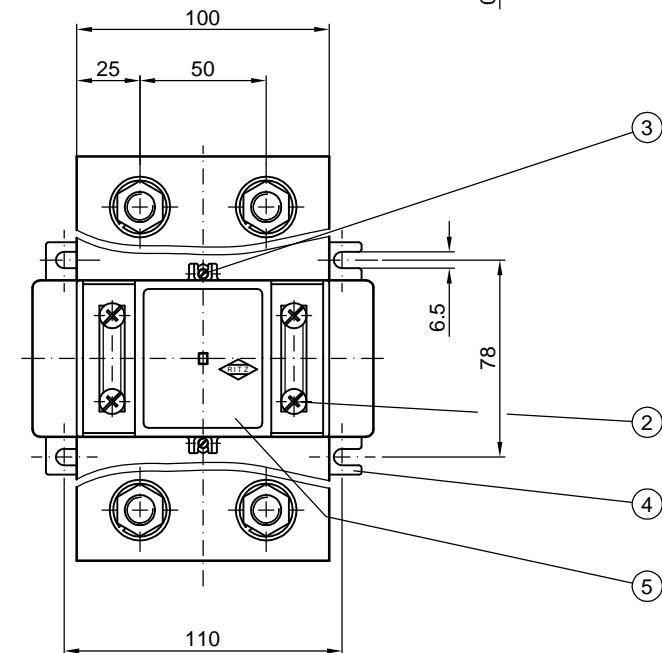

500-1600 A

1. Sekundärabdeckung, durchsichtig und auf Wunsch plombierbar
Secondary terminal cover, transparent and sealable on request
2. Sekundäranschluß M5; Schraube Plus-Minus Schlitz; max. 4mm²(flexibel)/6mm²(massiv); Anziehdrehmoment 3.5 Nm
Secondary terminals M5; Phillips recessed head screw; max. 4mm²(flexible)/6mm²(solid); tightening torque 3.5 Nm
3. Primärleiterbefestigung; M4x40, Gewindestift mit Schlitz; max. 2 Nm
Primary fixing device; M4x40, slotted headless screw; max. 2 Nm
4. Fußbefestigung
Mounting feet
5. Leistungsschild
Rating plate

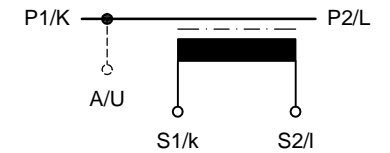
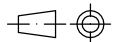

EKN	VNT	VNO	RM	RKN	Benennung/designation		
				Datum/date	Name/name	KSS 311 Schienen Stromwandler Bar type C.T.	
				Bear. drawn	28.11.1994		IE
				Gepr. checked			
				Gepr. checked			
1	090005	12.01.09	Hu				
Index	Anderung revision	Datum date	Name/name	Zeichnungsnummer/drawing number MB3.4770			Index
Urheberschutz n. DIN 34 copyright acc. to DIN 34				RITZ Instrument Transformers		1	
Maßstab/scale	1:2	7360		Dateiname data file name	M00477011.dwg	(Ers.f.)/(sub.for)	(Ers.d.)/(sub.by)